

BOLTED SERIES

1/2"

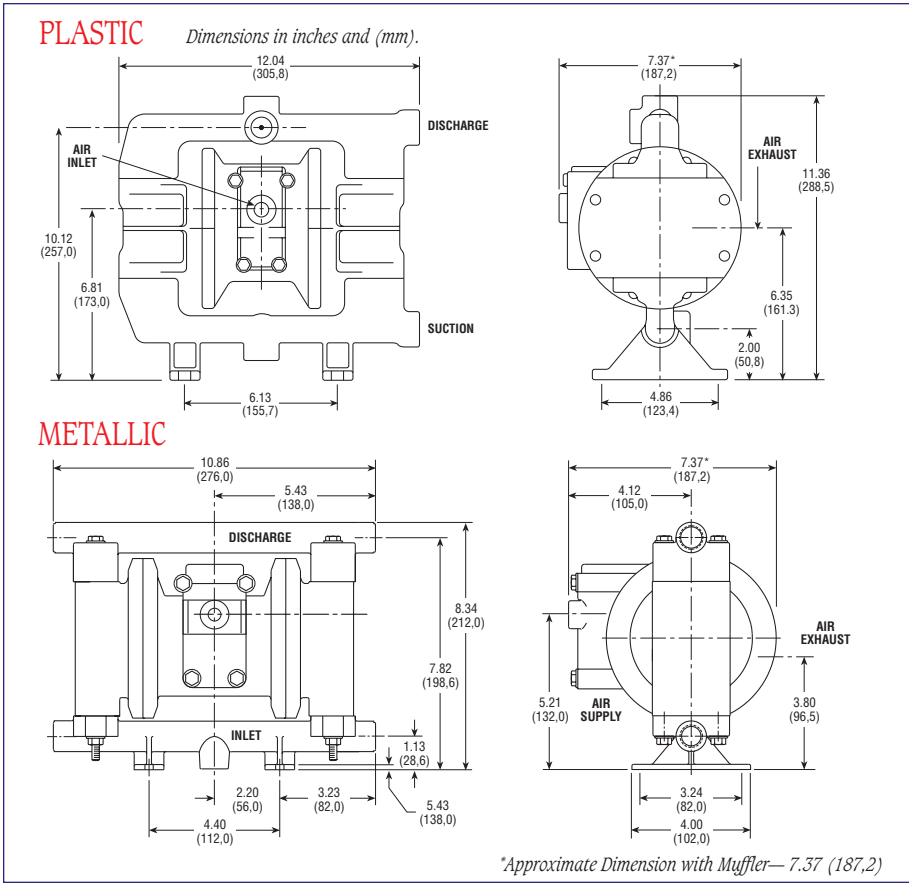
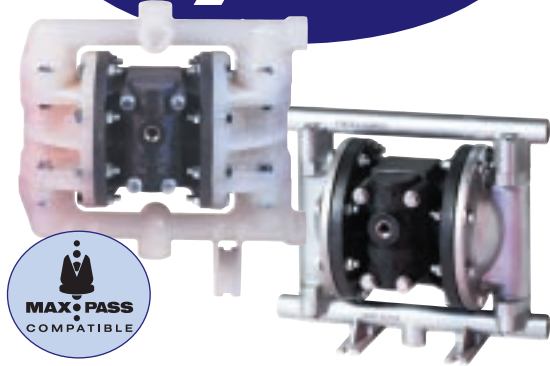

PLASTIC MODELS:

PB-05 (Polypropylene/Geolast®)	9 lbs. (4,1 kg.)
PE-05 (Polypropylene/Santoprene®/EPDM)	9 lbs. (4,1 kg.)
PT-05 (Polypropylene/PTFE)	9 lbs. (4,1 kg.)
PV-05 (Polypropylene/Viton®)	9 lbs. (4,1 kg.)
NB-05 (Nylon/Geolast®)	9 lbs. (4,1 kg.)
NT-05 (Nylon/PTFE)	9 lbs. (4,1 kg.)
CB-05 (Conductive Nylon/Geolast®)	12 lbs. (5,4 kg.)
CT-05 (Conductive Nylon/PTFE)	12 lbs. (5,4 kg.)
KE-05 (PVDF/Santoprene®/EPDM)	12 lbs. (5,4 kg.)
KT-05 (PVDF/PTFE)	12 lbs. (5,4 kg.)
KV-05 (PVDF/Viton®)	12 lbs. (5,4 kg.)

METALLIC MODELS:

AB-05 (Aluminum/Geolast®)	10 lbs. (4,5 kg.)
AE-05 (Aluminum/Santoprene®/EPDM)	10 lbs. (4,5 kg.)
AT-05 (Aluminum/PTFE)	10 lbs. (4,5 kg.)
AV-05 (Aluminum/Viton®)	10 lbs. (4,5 kg.)
SB-05 (316 SS/Geolast®)	19 lbs. (8,6 kg.)
SE-05 (316 SS/Santoprene®/EPDM)	19 lbs. (8,6 kg.)
SP-05 (316 SS/PTFE)	19 lbs. (8,6 kg.)
SV-05 (316 SS/Viton®)	19 lbs. (8,6 kg.)

All fasteners are 18-8 stainless steel (comparable to 302-304).

SPECIFICATIONS:

- Capacity:** Adjustable 0 – 17 GPM (64,6 liters/min.)
- Maximum Temperature:**
 - KT-05 Model 200°F (93°C)
 - Other Plastic Models 150°F (66°C)
 - Metallic Models 200°F (93°C)
- Maximum Air Pressure:** All Models 120 PSI (8,0 bar)
- Minimum Air Pressure:** All Models 20 PSI (1,2 bar)
- Dry Lift Capacity @ 120 PSI (8 bar):**
 - Models w/PTFE balls 10 ft. (3 meters)
 - Other Ball Check models. 15 ft. (4,5 meters)
 - Plastic models w/Max-Pass valve . 20 ft. (6 meters)
- Maximum Solids:** 1/8" (3,2 mm)
- Optional Max-Pass valves 3/8" (9,5 mm)

Air Supply:
 Inlet 1/4" NPT Female
 Outlet. 3/8" NPT Female

- *Muffler supplied*
- Fluid Inlet/Discharge:**
 - Models 1/2" NPS Female (BSP compatible)
 - *Stock models have a side port. Optional center, top or dual ports must be specified when ordering (See options page for code). Fluid is not separated within the single piece manifold when dual ports are specified.*

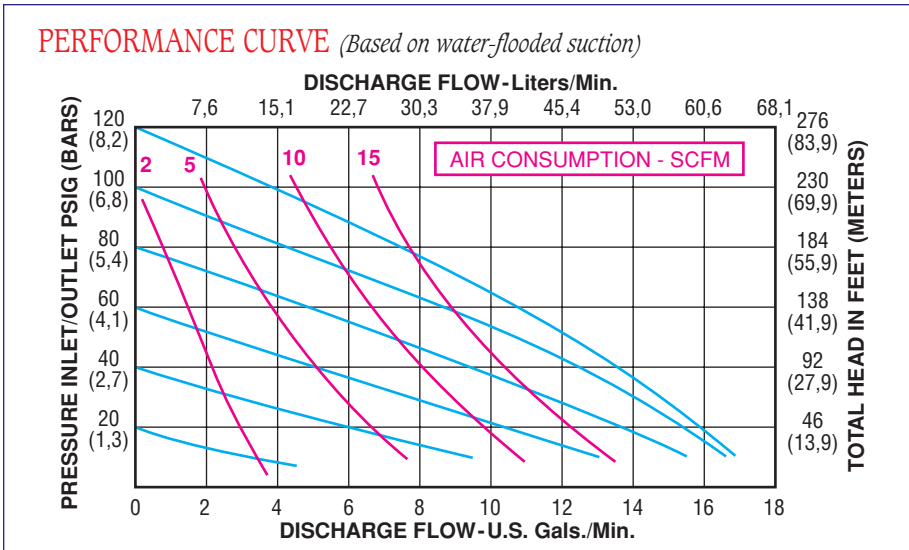

NEW OPTIONAL MAX-PASS VALVE SYSTEM (Plastic Pumps Only)

- Increases solids handling capability by 300% and suction lift by 25%
- Up to 3/8" solids for the 1/2" bolted plastic pumps
- Abrasion resistant
- 360° mounting capability
- To order the Max-Pass valve system add the following code to the model number: -M4(Nitrile), M5(EPDM), M40 (Viton FDA)

Ideal for inks, paints, slurries, and other specialized applications